



## GENERAL DESCRIPTION

Delta **Fire Hydrant Valves** are manufactured to BS5041 Part 1 and are constructed from corrosion resistant LG2 Gunmetal for suitability to both On-Shore & Off-Shore applications. Delta Globe Valves and Pressure Regulating Valves (PRV's) are Dual Seat design whereby the valve seat is manufactured in a hard rubber with an additional secondary metal to metal seat for enhanced long-term performance.

Globe and PRV valves are supplied in a range of flanged or threaded inlet models with a wide choice of British or International outlet adaptors for compatibility to existing equipment. Globe valves are available in Horizontal, Right Angle, Bib-Nose & Oblique patterns. PRV's are available in Bib-Nose pattern only.

Delta also supply bespoke fabricated Wet Pillar Hydrants to customer's specifications. These are available in a number of materials including painted carbon steel or 316 stainless steel.

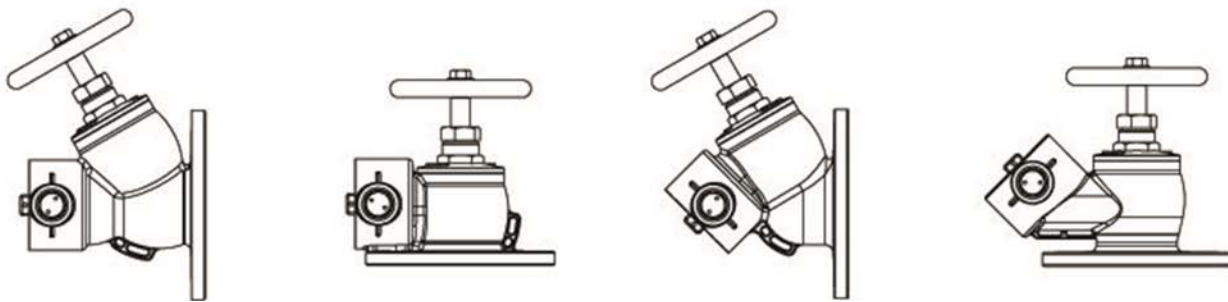

## TECHNICAL DATA

Flanged Inlet	PN16	PN16	PN16	Table D/E	Table D/E	ANSI	ANSI
Size	1½"	2"	2½"	2½"	3"	2½"	3"
Diameter (mm)	150	165	185	165	184	178	191
PCD (mm)	110	125	145	127	146	140	152

Also available with alternative flanged, BSP & NPT threaded inlets

## WEIGHTS

Valve Type	Right Angle	Horizontal	Bib-Nose	Oblique
Weight-Flanged	9kg	9kg	9kg	9kg
Weight-Threaded	8kg	8kg	8kg	8kg

## PRESSURE REGULATING VALVES

Delta Pressure Regulating Valves have been designed to maintain a uniform firefighting pressure for fire mains. These valves can be used in high-rise buildings to ensure the pressure will remain constant irrespective of location. The Delta PRV's can also be used in ring mains where normal pressure may exceed the safe operating pressures of the portable firefighting equipment. Manufactured in corrosion resistant LG2 Gunmetal the PRV's are perfectly suited for use in marine environments.

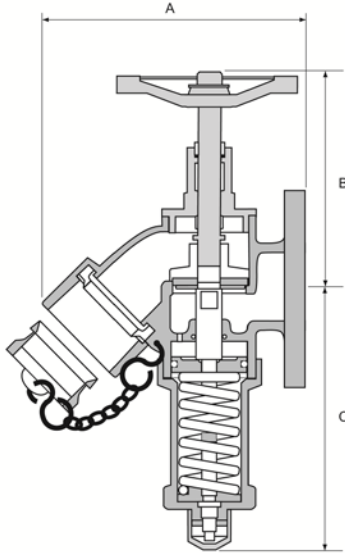

**Standard Outlet:** 2½" Instantaneous Female.

Optional International Outlet adaptors available.

**Standard Inlet:** 2½" ANSI 150lb/ PN16 / BS10 Flange  
(Alternative flanges & threads available)

Inlet Type	Flanged Inlet	Threaded Inlet
Dim A	225mm	235mm
Dim B	Open: 178mm Closed: 158mm	Open: 178mm Closed: 158mm
Dim C	230mm	230mm



## TECHNICAL DATA

Pressure Regulating Valves (PRV's)	The static outlet pressure of the spring can be set between the following parameters. The normal factory setting is set at 7 bar but can be adjusted as required
Inlet Pressure:	5 bar to 20 bar
Outlet Pressure:	5 bar to 9 bar (adjustable)
Working Pressure:	20 bar (290 psi) at 0 to -38°C
Seat Test:	22 bar (319 psi)
Body Test:	30 bar (435 psi)
Weight:	12kg



## PILLAR HYDRANTS

Delta offers a comprehensive range of **Wet Pillar Hydrants** available in a choice of materials and colour finishes.

Utilising Delta Globe Valves or PRV Valves, the Delta Wet Pillar Hydrants are ideally suited to a wide range of Industry applications, most commonly used on Petrochemical Sites, Industrial Facilities, Tank Farms, Port Authorities etc, etc.



**DELTA FIRE**

Broadland Business Park, Norwich, Norfolk, UK, NR7 0FE

T: +44(0)1603 735000 | E: sales@deltafire.co.uk | E: export@deltafire.co.uk

deltafire.co.uk